

ITX-Y3568 主板产品规格书

ITX-Y3568 Mainboard Specification

版本 Version	V1.0
日期 Date	2023-07-24

敬告：本档版权归内容原创公司所有，并保留一切权力。档内容如有修改更新，请联系提供方获取最新版本，恕不另行通知。

Note: This document is copyrighted by the content original company and all rights reserved. If the contents of the document are updated, please contact the provider for the latest version without notice.

修改记录 Changelog

1.0.0	2023-07-24	中英文合并版本。Chinese and English merged version.
-------	------------	---

目录 Contents

1	主芯片简介 RK3568 BRIEF	5
2	产品概述 PRODUCT OVERVIEW	6
3	规格清单 SPECIFICATION LIST	8
4	接口定义 INTERFACE DEFINITION	11
➤	J1 USB OTG 接口 USB OTG HEADER	11
➤	J2 VGA+HDMI 输出插座 VGA + HDMI OUTPUT SOCKET	11
➤	J3 USB 2.0 双排接口 USB 2.0 DIP HEADER	11
➤	J4 USB 2.0 双排接口 USB 2.0 DIP HEADER	11
➤	J5 USB 2.0 接口 USB 2.0 HOST HEADER.....	12
➤	J6 USB 2.0 接口 USB 2.0 HOST HEADER.....	12
➤	J7 USB 2.0 直通接口 USB 2.0 HOST DIRECT HEADER	12
➤	J8 POE 受电接口 POE PD HEADER	13
➤	J9 RJ45 以太网+双层 USB 插座 RJ45 ETHERNET + DOUBLE USB SOCKET	13
➤	J10 RJ45 以太网+双层 USB 插座 RJ45 ETHERNET + DOUBLE USB SOCKET	13
➤	J11 PCIE 4G/5G 插座 M-PCIE 4G/5G SOCKET	13
➤	J12 MICRO-SIM 卡座 MICRO-SIM CARD SOCKET.....	13
➤	J14 WiFi 天线座 WiFi ANTENNA IPEX.....	14
➤	J15 音频输入接口 AUDIO INPUT HEADER.....	14
➤	J16 喇叭接口 SPEAKER HEADER	14
➤	J18 音频扩展接口 AUDIO EXTENSION INTERFACE	14
➤	J17 耳机+MIC 插座 HEADPHONES + MIC IN JACK	15
➤	J19 DC-12V 插座 DC-12V JACK	15
➤	J20 DC-12V 输入接口 DC-12V INPUT HEADER	15
➤	J21 ATX 12V-IN 电源接口 ATX 12V-IN POWER HEADER	15
➤	J23 前置面板接口 FRONT PANEL HEADER.....	16
➤	J24 遥控-LED 接口 REMOTE CONTROL & LED HEADER.....	16
➤	J25 TF 卡插座 TF CARD SOCKET	16
➤	J26 KIO 按键接口 KIO KEYPAD HEADER.....	17
➤	J27 LVDS 背光控制接口 BACKLIGHT CONTROL HEADER	17
➤	J28 EDP 背光控制接口 EDP BACKLIGHT CONTROL HEADER	17
➤	J29 LVDS 接口 LVDS HEADER.....	18
➤	J30 LVDS 电压接口 LVDS VOLTAGE HEADER.....	18

➤	J31 EDP 电压接口 EDP VOLTAGE HEADER.....	19
➤	J32 EDP 接口 EDP HEADER.....	19
➤	J33 MIPI 屏 FPC 接口 MIPI PANEL FPC CONNECTOR.....	19
➤	J34 VGA 扩展接口 VGA OUTPUT HEADER	21
➤	J35 双 MIPI 摄像头 FPC 接口 DUAL MIPI CAMERA FPC CONNECTOR.....	21
➤	J36 HDMI 输入插座 HDMI INPUT JACK.....	22
➤	J37 数据串口 2 DATA SERIAL PORT 2	22
➤	J38 数据串口 3 DATA SERIAL PORT 3	23
➤	J39 双层 DB-9 内置串口 DOUBLE DB-9 SERIAL PORT.....	23
➤	J40 数据串口 4 DATA SERIAL PORT 4	24
➤	J41 数据串口 5 DATA SERIAL PORT 5	24
➤	J42 数据串口 7 DATA SERIAL PORT 7	25
➤	J43 数据串口 8 DATA SERIAL PORT 8	25
➤	J44 数据串口 9 DATA SERIAL PORT 9	25
➤	J45 I2C 总线接口 I2C BUS HEADER.....	26
➤	J46 I2C FPC 接口 I2C FPC HEADER.....	26
➤	J47 CAN 接口 1 CAN HEADER 1.....	26
➤	J48 CAN 接口 2 CAN HEADER 2.....	27
➤	PWR/HDD 双层 LED 灯 DUAL-TIER LED	27
➤	SW1 系统复位按键 SYSTEM RESET BUTTON.....	27
➤	SW2 烧录模式按键 RECOVERY MODE BUTTON.....	27
5	物理尺寸 PHYSICAL SIZE.....	28
6	注意事项 ASSEMBLE PRECAUTIONS	29
7	软件指南 SOFTWARE GUIDE	31

1 主芯片简介 RK3568 Brief

RK3568 芯片具备高性能、高扩展应用特点。目前为瑞芯微 Rockchip 产品线中性价比最强的芯片，硬件规格在行业处领先地位。

- CPU：四核 64 位 Cortex-A55 架构，基于高端 22nm 工艺打造，主频最高 2.0GHz。
- GPU：ARM Mali-G52 2EE，支持 OpenGL ES 1.1/2.0/3.2，OpenCL 2.0，Vulkan 1.1，内嵌高性能 2D 加速硬件
- NPU：支持 1Tops 算力
- 多媒体：支持 4K 60fps H.265/H.264/VP9 视频解码；支持 1080P 100fps H.265/H.264 视频编码；支持 8M ISP，支持 HDR
- 显示：支持多屏异显；支持 EDP/HDMI2.0/MIPI/LVDS/24bit RGB/T-CON
- 接口：支持 USB2.0/USB3.0/PCIE3.0/PCIE2.1/SATA3.0/QSGMII



***相关功能为 CPU 内部特性，主板是否支持请以相应的接口说明为准。**

2 产品概述 Product Overview

ITX-Y3568 主板基于瑞芯微 RK3568 高性能大小核架构应用处理器平台，RK3568 主芯片集成四核 Cortex-A55、Mali-G52 2EE 高性能 GPU，主频最高可达 2.0GHz，具备超强的计算性能、2D/3D 图形处理能力和全高清视频编解码能力，完美支持 4Kx2K@60fps 超清解码和 4Kx2K HDMI 超清输出。

ITX-Y3568 mainboard is based on Rockchip RK3568 high-performance application processor platform. RK3568 is a low power, high performance processor for computing, personal mobile internet devices and other smart device applications. It integrates quad-core Cortex-A55 clocked at up to 2.0GHz, with superior computing performance, 2D/3D graphics processing capabilities and Full HD video codec capabilities. It perfectly supports 4Kx2K@60fps decoding and 4Kx2K HDMI output.

此款主板专门针对**自助服务终端 (Self-Service Terminal)** 应用进行严格选材和设计，紧凑的尺寸和丰富的接口方便其集成到整机中，为最终的产品带来流畅的体验和超强的性能，可应用于数字标牌、触摸互动、消费电子、娱乐系统等行业。

This mainboard is specially designed for **Self-Service Terminal** applications with strict material selection and design. The compact size and rich interface facilitate its integration into the complete machine, bringing a smooth experience and superior performance to the final product. It can be applied to digital signage, touch interactive, consumer electronics, entertainment systems and other industries.

ITX-Y3568 V1.0 主板实物照片接口示意图如下所示。

ITX-Y3568 V1.0 mainboard actual interface diagram as shown below.

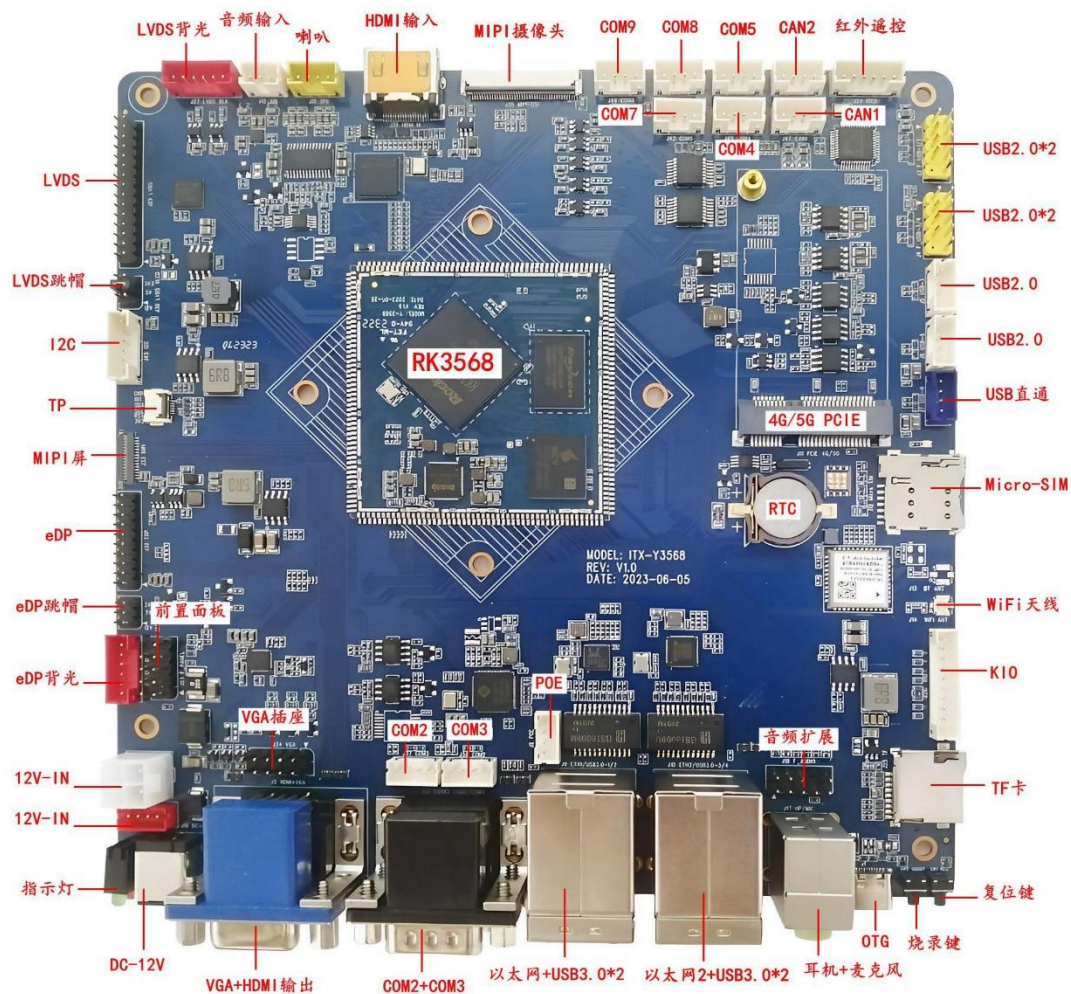

俯视图 Top view

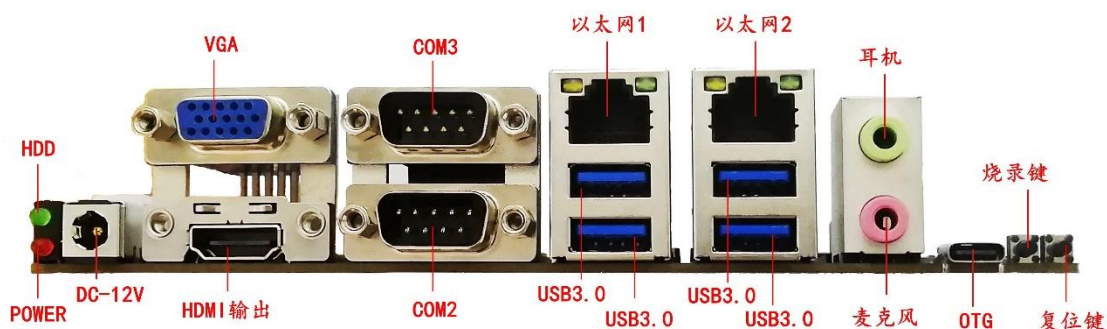

正面图 Front view

3 规格清单 Specification List

ITX-Y3568 的系统功能和接口特性如下表所示。包括 Y-3568 核心板和 ITX-Y3568 底板。ITX-Y3568's system functions and interface features are shown in the following table. It is composed of Y-3568 core board and ITX-Y3568 base board.

Y-3568 核心板的功能和接口如下表所示。Y-3568 core board features are listed below.

功能&接口 Function & Interface	详细描述 Detailed Description
CPU	RK3568 Cortex-A55 四核, 最高主频 2.0GHz RK3568 Cortex-A55 quad-core, up to 2.0GHz
DDR	LPDDR4 2GB (4GB 8GB 可选) LPDDR4 2GB (4GB 8GB optional)
存储 Storage	默认标配 16GB EMMC NAND 芯片, 可扩展至最大 128GB The default comes with an 16GB EMMC NAND chip that can scale up to 128GB
操作系统 Operating System	推荐安卓 11, 可选 Linux Buildroot/Debian 10/Ubuntu-18.04 Recommended Android 11, Linux Buildroot/Debian 10/Ubuntu-18.04 optional

ITX-Y3568 的系统功能和接口特性如下表所示。ITX-Y3568's system functions and interface features are shown in the following table.

功能&接口 Function & Interface	详细描述 Detailed Description
HDMI 输出 HDMI Output	HDMI 2.0a 标准显示接口, 最高支持 4K 输出 HDMI 2.0a standard display interface supports up to 4K output
LVDS	30 针行业标准双路 LVDS 接口, 支持 VESA/JEITA 格式, 最高支持 1080P 输出 30-pin industry-standard dual LVDS supporting VESA/JEITA format up to 1080P output
EDP	20 针行业标准 EDP 接口, 支持 1~4 通道模式, 最高支持 1080P 输出 (EDP 与 VGA 二选一) 20-pin industry-standard EDP supporting 1~4 lanes format up to 1080P output
MIPI-DSI	31-Pin FPC MIPI-DSI 显示接口, 最高支持 1920x1200 输出 31-Pin FPC MIPI-DSI display port supporting up to 1920x1200
VGA 输出	行业标准 DB-15 VGA 输出接口和 9 芯排针接口, 最高支持 1080P 输出 (EDP 与 VGA 二选一) Industry-standard DB-15 and 9-pin header VGA output up to 1080P
HDMI 输入 HDMI Input	HDMI 2.0/1.4b 标准输入接口, 支持 720P 和 1080P 信号 HDMI 2.0/1.4b standard video input interface supports 720P and 1080P signals
功放输出 Amplifier output	8 欧·6W 双路音频功放输出 8 Ohm 6W Dual Audio Amplifier Output
耳机输出 Headphone Output	左右声道耳机输出 (音频插座) Stereo Headphone Output (Audio Jack)
MIC 输入 MIC Input	差分 MIC 输入 (音频插座) Differential MIC input (Audio Jack)
PCIE 4G/5G	1 路行业标准 PCIE 4G/5G 模块接口, 支持 Micro-SIM 卡插槽

功能&接口 Function & Interface	详细描述 Detailed Description
	1 Industry standard m-PCIE 4G module interface with Micro-SIM card socket
eSIM	板载 eSIM 芯片 (选配), 支持 PCIE 4G/5G 模块的网络通讯 Onboard eSIM chip (optional), supports network communication of the PCIE 4G/5G module
USB 接口 USB Interface	4 个外置横插接口 (USB Host 3.0x4), 3 个内置排针 (USB Hub 2.0x2 和 USB Host 2.0 直通 x1), 2 组前置 USB (USB Hub 2.0x4) 4 horizontal connectors (USB Host 3.0x4), 3 pin headers (USB Hub 2.0x2 and USB Host 2.0x1 direct), 2 sets of USB front (USB Hub 2.0x4)
串口 Serial Port	2 路 DB-9 串口, 带信号和电源隔离 (复用); 4 个 TTL/RS-232/RS-485 兼容内置, 3 个 TTL/232 兼容内置 2 TTL/232/485 DB-9 serial port, with signal & power isolation (reuse); 4 TTL/RS-232/RS-485 compatible, 3 TTL/RS-232 compatible
USB 摄像头 USB Camera	支持 800 万像素以内 USB 摄像头 Support USB camera within 8 million pixels
双 MIPI 摄像头 Dual MIPI Camera	40-Pin FPC 双 MIPI 通道高清摄像头接口, 双目 LED_5V 控制 IO=#108(推荐 SV-ZI16-90 REV1.1) 40-Pin FPC Dual MIPI HD camera port, binocular LED_5V controls IO=#108(E.g. SV-ZI16-90 REV1.1)
WiFi	内置高性能 SDIO 接口 WiFi6 模块, 支持 IEEE 802.11 a/b/g/n/ac/ax, 默认配置 2.4/5GHz WiFi Built-in high performance SDIO interface WiFi6 module, support IEEE 802.11 a/b/g/n/ac/ax
蓝牙 Bluetooth	内置高性能串口 BT 模块, 支持 V2.1+EDR/BT v3.0/BT v3.0+HS/BT v4.0/BT v5.0 Built-in high performance serial interface BT module (optional) with support for V2.1+EDR/BT v3.0/BT v3.0+HS/BT v4.0/BT v5.0
以太网口 Ethernet	2 路 10/100/1000M 自适应以太网 RJ45 网口+ 提供 4 芯 PoE PD 插座 2 port 10/100/1000M Adaptive Ethernet RJ45 connector with 4-Pin PoE PD header
背光控制 Backlight Control	2 路行业标准液晶屏背光控制接口, 支持背光开关和亮度调节 2 ways Industry standard LCD backlight control header, support for backlight switch and brightness adjustment
红外遥控 Infrared RC	标准红外接收排针接口 Standard infrared receiver pin header
GPIO 信号 GPIO Signals	8 路 GPIO 信号, 可扩展 GPIO 按键和/或 3.3V 输入/输出 8-way GPIO signals for such as GPIO buttons and/or 3.3V digital input/output
CAN 总线 CAN Bus	2 路 CAN 排针接口, 可扩展 CAN 总线外设 2 CAN pin header for CAN Bus peripherals
TF 卡 Micro SD Card	自弹式 TF 卡插座, 最高支持 256GB TF 卡 Self-elastic micro SD card socket, up to 256GB capacity
I2C 总线 I2C Bus	I2C 排针+FPC, 可扩展 I2C 电容屏等 I2C pin header with FPC for I2C capacitive screen and etc
前置面板 Front Panel	1 路 F_PANEL 接口, 用于连接到前面板的双排插针 1 F_PANEL port for connecting to the double-row pins on the front panel
音频扩展 Audio Extension	1 路 F_AUDIO 接口, 用于接前置耳机与麦克风的接口 1 F_AUDIO port used to connect the front earphone to the microphone
实时时钟	超低功耗 RTC 电路 (带 CR1220 纽扣电池), 并可支持定时开关机

功能&接口 Function & Interface	详细描述 Detailed Description
Real Time Clock	Ultra-low-power RTC circuit (CR1220 battery) with timer and alarm functionalities
指示灯 LED Indicator	红色待机指示和绿色工作指示灯 Red LED indicator for standby and green LED indicator for running
按键 Buttons	烧录键 (RECOVERY) 和复位键 Recovery mode button and reset button
重力感应 Gravity Induction	支持重力感应功能, 可实现屏幕自动旋转 Support gravity sensing function to achieve automatic screen rotation
人脸授权 Face Authorization	支持旷视人脸芯片, 提供算法硬件授权 Support for Megvii face chip, provide algorithm hardware authorization
电源输入 DC Input	支持 9~15V 宽电压直流电源输入和 ATX 12V-IN 电源 Supports 9~15V wide voltage DC power input
环境要求 Ambient Requirement	工作温度 -20°C ~ 70°C, 工作湿度 0%~95% (不结露) Working temperature -20°C ~ 70°C, working humidity 0%~95% (non-condensing)
物理尺寸 Physical Size	长*宽*高 (170mm*170mm*32.2mm) , PCB 正面高度 30.7mm Length*Width*Height (170mm*170mm*32.2mm), PCB top side height 30.7mm

4 接口定义 Interface definition

➤ J1 USB OTG 接口 USB OTG Header

【J1】USB 3.0 Type-C 插座，此接口仅用于进行系统烧录和 ADB 调试。 [J1] USB 3.0 Type-C Socket, this port should only be used as system burn or ADB connection.

➤ J2 VGA+HDMI 输出插座 VGA + HDMI Output Socket

【J2】标准 DB-15 VGA 和 HDMI 2.0 输出插座。 [J2] Standard DB-15 VGA and HDMI 2.0 Output Sockets.

注意：J2 VGA 和 J32 EDP 接口内部信号复用，只能二选一。

➤ J3 USB 2.0 双排接口 USB 2.0 DIP Header

【J3】USB 2.0 接口（双排 2.54mm-方孔为 1 脚）。 [J3] USB 2.0 header (DIP 2.54mm-Square pad is pin 1).

Pin#	Definition	Note	Pin#	Definition	Note
1	5V	5V 输出 Power output 5V	2	5V	5V 输出 Power output 5V
3	D-	USB 差分数据+ USB Differential Data+	4	D-	USB 差分数据+ USB Differential Data+
5	D+	USB 差分数据- USB Differential Data-	6	D+	USB 差分数据- USB Differential Data-
7	GND	数字地 Digital Ground	8	GND	数字地 Digital Ground
9	空	防呆 Null	10	GND	数字地 Digital Ground

注意：此端口为主芯片 USB2_HOST2 口 Hubx7 扩展端口。

➤ J4 USB 2.0 双排接口 USB 2.0 DIP Header

【J4】USB 2.0 接口（双排 2.54mm-方孔为 1 脚）。 [J4] USB 2.0 header (DIP 2.54mm-Square pad is pin 1).

Pin#	Definition	Note	Pin#	Definition	Note
1	5V	5V 输出 Power output 5V	2	5V	5V 输出 Power output 5V
3	D-	USB 差分数据+ USB Differential Data+	4	D-	USB 差分数据+ USB Differential Data+
5	D+	USB 差分数据- USB Differential Data-	6	D+	USB 差分数据- USB Differential Data-
7	GND	数字地 Digital Ground	8	GND	数字地 Digital Ground
9	空	防呆 Null	10	GND	数字地 Digital Ground

注意：此端口为主芯片 USB2_HOST2 口 Hubx7 扩展端口。

➤ J5 USB 2.0 接口 USB 2.0 Host Header

【J5】USB 2.0 接口（单排 2.0mm-方孔为 1 脚）。[J5] USB 2.0 Host Header (SIP 2.0mm-Square pad is pin 1)

Pin#	Definition	Note
1	GND	数字地 Digital Ground
2	D+	USB 差分数据+ USB Differential Data+
3	D-	USB 差分数据- USB Differential Data-
4	5V	5V 输出 Power output 5V

注意：此端口为主芯片 USB2_HOST2 口 Hubx7 扩展端口。

➤ J6 USB 2.0 接口 USB 2.0 Host Header

【J6】USB 2.0 接口（单排 2.0mm-方孔为 1 脚）。[J6] USB 2.0 Host Header (SIP 2.0mm-Square pad is pin 1)

Pin#	Definition	Note
1	GND	数字地 Digital Ground
2	D+	USB 差分数据+ USB Differential Data+
3	D-	USB 差分数据- USB Differential Data-
4	5V	5V 输出 Power output 5V

注意：此端口为主芯片 USB2_HOST2 口 Hubx7 扩展端口。

➤ J7 USB 2.0 直通接口 USB 2.0 Host Direct Header

【J7】USB 2.0 Host 直通接口（单排 2.0mm-方孔为 1 脚）。[J7] USB 2.0 Host Direct Header (SIP 2.0mm- Square pad is pin 1).

Pin#	Definition	Note
1	GND	数字地 Digital Ground
2	D+	USB 差分数据+ USB Differential Data+
3	D-	USB 差分数据- USB Differential Data-
4	5V	5V 输出 Power output 5V

注意：此端口为主芯片 USB2_HOST3 口直通 USB 口。

➤ J8 POE 受电接口 POE PD Header

【J8】POE 受电接口（单排 2.0mm-方孔为 1 脚）。[J8] POE PD Header (SIP 2.0mm-Square pad is pin 1)

Pin#	Definition	Note
1	CT1	中心抽头1 Transformer Center1
2	CT2	中心抽头2 Transformer Center2
3	CT3	中心抽头3 Transformer Center3
4	CT4	中心抽头4 Transformer Center4

注意：POE 受电接口电源来自于 J9 以太网口，此接口外接 POE 受电转换板进行 12V 供电转换，12V 电源的电流大小受 POE 交换机的供电能力和转接板转换能力影响，典型电流在 2.1A。此接口支持网线 1/2 线为正、3/6 线为负的 POE 供电设备，也可以接网线 4/5 线为正、7/8 线为负的 POE 供电设备。

➤ J9 RJ45 以太网+双层 USB 插座 RJ45 Ethernet + Double USB Socket

【J9】RJ45 以太网+双层 USB 插座。三层组合插座，自上而下，分别是 RJ45 千兆以太网插座、USB host 3.0、USB host 3.0。**注意：此端口 USB 为主芯片 USB3_HOST1 口 Hubx4 扩展端口。**

[J9] RJ45 Ethernet + Double USB Socket. Three-layer combination socket. From top to bottom, they are RJ45 Gigabit Ethernet Jack, USB host 3.0 and USB host 3.0.

➤ J10 RJ45 以太网+双层 USB 插座 RJ45 Ethernet + Double USB Socket

【J10】扩展 RJ45 以太网+双层 USB 插座。三层组合插座，自上而下，分别是扩展 RJ45 千兆以太网插座、USB host 3.0、USB host 3.0。**注意：此端口 USB 为主芯片 USB3_HOST1 口 Hubx4 扩展端口。**

[J10] Extended RJ45 Ethernet + Double USB Socket. Three-layer combination socket. From top to bottom, they are extended RJ45 Gigabit Ethernet Jack, USB host 3.0 and USB host 3.0.

➤ J11 PCIE 4G/5G 插座 m-PCIE 4G/5G Socket

【J11】标准 PCIE 4G/5G 插座。[J11] Standard m-PCIE 4G/5G Socket.

➤ J12 Micro-SIM 卡座 Micro-SIM Card Socket

【J12】Micro-SIM 卡座。[J12] Micro-SIM Card Socket.

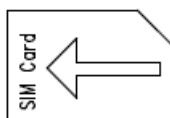

注意：SIM 卡座是常规中卡的卡槽，插卡时请注意 SIM 卡缺口朝外插入。

➤ J14 WiFi 天线座 WiFi Antenna IPEX

【J14】标准 IPEX 3dBi 天线座 (Φ2.0mm)。[J14] Standard IPEX 3dBi antenna connector (Φ2.0mm).

➤ J15 音频输入接口 Audio Input Header

【J15】音频输入接口 (单排 2.0mm-方孔为 1 脚)。[J15] Audio input header (SIP 2.0mm-Square pad is pin 1).

Pin#	Definition	Note
1	RIN	线路输入右声道 Line input right channel
2	GND	音频地 Audio Ground
3	LIN	线路输入左声道 Line input left channel

➤ J16 喇叭接口 Speaker Header

【J16】喇叭接口 (单排 2.0mm-方孔为 1 脚)。[J16] Speaker Header (SIP 2.0mm-Square pad is pin 1).

Pin#	Definition	Note
1	OUTP_R+	喇叭右声道+ Speaker right channel +
2	OUTN_R-	喇叭右声道- Speaker right channel -
3	OUTN_L-	喇叭左声道- Speaker left channel -
4	OUTP_L+	喇叭左声道+ Speaker left channel +

➤ J18 音频扩展接口 Audio Extension Interface

【J18】音频扩展接口 (双排 2.54mm-方孔为 1 脚)。[J18] Audio Line Output (DIP 2.54mm-Square pad is pin 1).

Pin#	Definition	Note	Pin#	Definition	Note
1	MIC-L	模拟左声道麦克风输入 Analog left channel microphone input	2	GND	音频地 Audio Ground
3	MIC-R	模拟右声道麦克风输入 Analog right channel microphone input	4	SENSE	前置音频设备存在感应信号 Front audio induction signal
5	HP-R	模拟立体声输出右声道	6	MIC-DEL	前置麦克风检测信号

		Analog stereo output right channel			Front microphone detect signal
7	GND	音频地 Audio Ground	8	空	防呆 null
9	HP-L	模拟立体声输出左声道 Analog stereo output left channel	10	HP-DEL	前置耳机检测信号 Front headphone detect signal

➤ J17 耳机+MIC 插座 Headphones + MIC IN Jack

【J17】上层是三段式 3.5mm 耳机插座 (CTIA 美标定义-如下图), 支持耳机插入喇叭静音。下层是麦克风插座, 支持 2 和 3 段的麦克风。[J17] The upper layer is 3-Pole 3.5mm Headphone Jack (CTIA Standard jack). It supports insert detection for speaker mute. The lower level is 3.5mm Microphone Jack. Support for 2 and 3 segment microphones.



➤ J19 DC-12V 插座 DC-12V Jack

【J19】DC-12V 电源插座, 内正外负, 内芯直径 2.0mm, 外圈孔径 5.5mm。[J19] DC-12V power socket, positive outer and negative inner, inner pin diameter 2.0mm, outer ring diameter 5.5mm.

➤ J20 DC-12V 输入接口 DC-12V Input Header

【J20】DC-12V 输入接口 (单排 2.0mm-方孔为 1 脚), 信号同 J19/J21 插座。[J20] DC-12V Input Header (SIP 2.0mm-Square pad is pin 1).

Pin#	Definition	Note
1	12V	直流电源输入 (9~15V) DC Power Input (9~15V)
2	12V	直流电源输入 (9~15V) DC Power Input (9~15V)
3	GND	电源地 Power Ground
4	GND	电源地 Power Ground

➤ J21 ATX 12V-IN 电源接口 ATX 12V-IN Power Header

【J21】ATX 12V-IN 电源接口 (双排 4.2mm-方孔为 1 脚), 信号同 J19/J20 插座。[J21] ATX 12V-IN Power Header (SIP 4.2mm-Square pad is pin 1), it is the same to J19/J20 Jack.

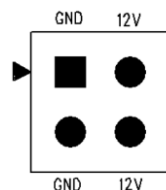

Pin#	Definition	Note
1	GND	电源地 Power GND
2	GND	电源地 Power GND
3	12V	电源输入 Power Input
4	12V	电源输入 Power Input

➤ J23 前置面板接口 Front Panel Header

【J23】前置面板接口（双排 2.54mm-方孔为 1 脚）。[J23] Front Panel Header (DIP 2.54mm-Square pad is pin 1).

Pin#	Definition	Note	Pin#	Definition	Note
1	HDD+	运行指示灯+ Running light +	2	LED+	电源指示灯+ Power indicator light+
3	HDD-	运行指示灯- Running light -	4	LED-	电源指示灯- Power indicator light-
5	RES-	复位键- Reset-	6	PW-	电源开关- Power switch-
7	RES+	复位键+ Reset+	8	PW+	电源开关+ Power switch+
9	GND	数字地 Digital Ground	10	空	防呆 Null

➤ J24 遥控-LED 接口 Remote Control & LED Header

【J24】遥控-LED 接口（单排 2.0mm-方孔为 1 脚）。[J24] Remote Control & LED Header (SIP 2.0mm-Square pad is pin 1).

Pin#	Definition	Note
1	5VS	5V Standby 供电输出 Power output 5V standby
2	GND	数字地 Digital Ground
3	IR	5V 电平红外遥控输入信号 5V level Irda remote control input signal
4	IO	3.3V 电平 GPIO 输入信号 3.3V level GPIO input signal
5	GREEN	运行指示灯信号 (外接绿灯) Running indicator for external green LED
6	RED	待机指示灯信号 (外接红灯) Standby indicator for external red LED

➤ J25 TF 卡插座 TF Card Socket

【J25】标准 TF 卡插座。[J25] Standard TF Card Socket.

➤ J26 KIO 按键接口 KIO Keypad Header

【J26】KIO 按键接口 (单排 2.0mm-方孔为 1 脚)。[J26] KIO Keypad Header (SIP 2.0mm-Square pad is pin 1).

Pin#	Definition	Note
1	3V3	3.3V 供电 3.3V Supply
2	K1	按键/IO [软件编号66] Keypad/IO
3	K2	按键/IO [软件编号65] Keypad/IO
4	K3	按键/IO [软件编号64] Keypad/IO
5	K4	按键/IO [软件编号63] Keypad/IO
6	K5	按键/IO [软件编号145] Keypad/IO
7	K6	按键/IO [软件编号4] Keypad/IO
8	K7	按键/IO [软件编号61] Keypad/IO
9	K8	按键/IO [软件编号62] Keypad/IO
10	GND	数字地 Digital Ground

说明: 注意所有 KIO 信号均可以通过单独的软件版本调整为常规 GPIO 使用 (电平为 3.3V)。Note: All KIO signals can be adjusted to regular GPIO via a separated software version (level is 3.3V).

➤ J27 LVDS 背光控制接口 Backlight Control Header

【J27】LVDS 背光控制接口 (单排 2.0mm-方孔为 1 脚)。[J27] LVDS Backlight Control Header (SIP 2.0mm-Square pad is pin 1).

Pin#	Definition	Note
1	12V	If the current exceeds 2A, external 12V is recommended
2	12V	如果电流超过2A 则建议外接12V 供电
3	EN	默认输出5V The default output is 5V
4	ADJ	3.3V 方波 (1KHz 频率) 3.3V square wave (1KHz Freq.)
5	GND	电源地 Power Ground
6	GND	电源地 Power Ground

注意: 如果外部 DC 输入电源超过 12V, 则请务必确认液晶屏背光部分可以承受相应的电压。

➤ J28 EDP 背光控制接口 EDP Backlight Control Header

【J28】EDP 背光控制接口 (单排 2.0mm-方孔为 1 脚)。[J28] EDP Backlight Control Header (SIP 2.0mm-Square pad is pin 1).

Pin#	Definition	Note
1	12V	If the current exceeds 2A, external 12V is recommended
2	12V	如果电流超过2A 则建议外接12V 供电

3	EN	默认输出5V The default output is 5V
4	ADJ	3.3V 方波 (1KHz 频率) 3.3V square wave (1KHz Freq.)
5	GND	电源地 Power Ground
6	GND	电源地 Power Ground

➤ J29 LVDS 接口 LVDS Header

【J29】双路 LVDS 接口 (双排 2.0mm-三角为 1 脚)。[J29] Dual LVDS header (DIP 2.0mm-Triangle tag is pin 1).

Pin#	Definition	Pin#	Definition
1	VLCD	2	VLCD
3	VLCD	4	GND
5	GND	6	GND
7	RX00-	8	RX00+
9	RX01-	10	RX01+
11	RX02-	12	RX02+
13	GND	14	GND
15	RX0C-	16	RX0C+
17	RX03-	18	RX03+
19	RXE0-	20	RXE0+
21	RXE1-	22	RXE1+
23	RXE2-	24	RXE2+
25	GND	26	GND
27	RXEC-	28	RXEC+
29	RXE3-	30	RXE3+

➤ J30 LVDS 电压接口 LVDS Voltage Header

【J30】LVDS 驱屏跳线接口 (双排 2.0mm-三角标志为 1 脚)。1 和 2 脚跳线帽短接则 J29 的 VLCD 为 12V, 3 和 4 脚跳线帽短接则 J29 的 VLCD 为 5V, 5 和 6 脚跳线帽短接则 J29 的 VLCD 为 3.3V。请根据实际使用的液晶屏的逻辑电压调整跳线帽位置, 注意不要跳错位置否则会造成液晶屏和主板电路的损坏。

注意: 如果外部 DC 输入电源超过 12V, 则请务必确认液晶屏逻辑部分可以承受相应的电压。

[J30] LVDS Voltage Header (DIP 2.0mm-Triangle tag is pin 1). If pin 1 and 2 are jumper shorted, the VLCD of J29 is 12V. If pin 3 and 4 are jumper shorted, the VLCD of J29 is 5V. If pin 5 and 6 are jumper shorted, the VLCD of J29 is 3.3V. Please adjust the jumper position according to the actual logic voltage of the LCD screen. Be careful not to jumper to the wrong position or it may damage the LCD screen and the motherboard circuit.

➤ J31 EDP 电压接口 EDP Voltage Header

【J31】EDP 驱屏跳线接口（单排 2.0mm-方孔为 1 脚）。1 和 2 脚跳线帽短接则 J32 的 VLCD 为 12V，3 和 4 脚跳线帽短接则 J32 的 VLCD 为 5V，5 和 6 脚跳线帽短接则 J32 的 VLCD 为 3.3V。请根据实际使用的液晶屏的逻辑电压调整跳线帽位置，注意不要跳错位置否则会造成液晶屏和主板电路的损坏。

[J31] EDP Voltage Header (DIP 2.0mm-Square pad is pin 1). If pin 1 and 2 are jumper shorted, the VLCD of J32 is 12V. If pin 3 and 4 are jumper shorted, the VLCD of J32 is 5V. If pin 5 and 6 are jumper shorted, the VLCD of J32 is 3.3V. Please adjust the jumper position according to the actual logic voltage of the LCD screen. Be careful not to jumper to the wrong position or it may damage the LCD screen and the motherboard circuit.

➤ J32 EDP 接口 EDP Header

【J32】EDP 接口（双排 2.0mm-方孔为 1 脚）。[J32] EDP header (DIP 2.0mm-Square pad is pin 1).

Pin#	Definition	Pin#	Definition
1	VLCD	2	VLCD
3	GND	4	GND
5	TX0-	6	TX0+
7	TX1-	8	TX1+
9	TX2-	10	TX2+
11	TX3-	12	TX3+
13	GND	14	GND
15	AUX-	16	AUX+
17	GND	18	GND
19	3.3V	20	NC

注意：J32 EDP 和 J2 VGA 接口内部信号复用，只能二选一。

➤ J33 MIPI 屏 FPC 接口 MIPI Panel FPC Connector

【J33】MIPI 屏 FPC 接口（FPC-0.3mm 31-Pin **下接触**）。[J33] MIPI Panel FPC Connector (FPC-0.3mm 31-Pin **Bottom Contact**).

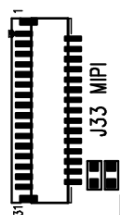

Pin#	Definition	Note
1	LED+	LED 阳极 LED Anode
2	LED+	LED 阳极 LED Anode
3	LED+	LED 阳极 LED Anode
4	NC	未连接 Not Connected
5	LED-	LED 阴极 LED Cathode
6	LED-	LED 阴极 LED Cathode
7	LED-	LED 阴极 LED Cathode
8	LED-	LED 阴极 LED Cathode
9	GND	数字地 Digital Ground
10	GND	数字地 Digital Ground
11	MIPI_D2P	+MIPI 差分数据输出 +MIPI differential lane2
12	MIPI_D2N	-MIPI 差分数据输出 -MIPI differential lane2
13	GND	数字地 Digital Ground
14	MIPI_D1P	+MIPI 差分数据输出 +MIPI differential lane1
15	MIPI_D1N	-MIPI 差分数据输出 -MIPI differential lane1
16	GND	数字地 Digital Ground
17	MIPI_CKP	+MIPI 差分时钟输出 +MIPI differential clock output
18	MIPI_CKN	-MIPI 差分时钟输出 -MIPI differential clock output
19	GND	数字地 Digital Ground
20	MIPI_D0P	+MIPI 差分数据输出 +MIPI differential lane0
21	MIPI_D0N	-MIPI 差分数据输出 -MIPI differential lane0
22	GND	数字地 Digital Ground
23	MIPI_D3P	+MIPI 差分数据输出 +MIPI differential lane3
24	MIPI_D3N	-MIPI 差分数据输出 -MIPI differential lane3
25	GND	数字地 Digital Ground
26	VDD-1V8	供电输出1.8V Power Supply 1.8V (默认不连接, 需加焊 R9232 0R)
27	RESET	复位信号 (1.8V 电平) Reset Signal in 1.8V
28	GND	数字地 Digital Ground
29	VDD-1V8	供电输出1.8V Power Supply 1.8V
30	VDD-3V3	供电输出3.3V Power Supply 3.3V
31	VDD-3V3	供电输出3.3V Power Supply 3.3V

➤ J34 VGA 扩展接口 VGA Output Header

【J34】VGA 扩展接口 (双排 2.54mm-方孔为 1 脚)。[J34] VGA Output Header (DIP 2.54mm-Square pad is pin 1).

Pin#	Definition	Note	Pin#	Definition	Note
1	RED	红色模拟信号 Red analog signal	2	GND	数字地 Digital Ground
3	GRN	绿色模拟信号 Green analog signal	4	GND	数字地 Digital Ground
5	BLUE	蓝色模拟信号 Blue analog signal	6	GND	数字地 Digital Ground
7	HS	数字水平同步信号 Horizontal synchronization signal	8	DATA	串行数据信号 Serial data signal
9	VS	数字垂直同步信号 Vertical synchronization signal	10	CLK	串行时钟信号 Serial clock signal

➤ J35 双 MIPI 摄像头 FPC 接口 Dual MIPI Camera FPC Connector

【J35】双 MIPI 摄像头 FPC 接口 (FPC-0.5mm 40-Pin 前插后翻盖**上/下接触**-三角为 1 脚)。[J35] Dual MIPI Camera FPC Connector (FPC-0.5mm 40-Pin **Top/Bottom Contact Triangle** Pin-1).

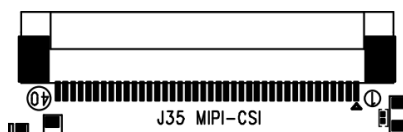

Pin#	Definition	Note
1	IR_AVDD_2V8	2.8V 红外摄像头供电 2.8V IR Camera Power Supply
2	RGB_AVDD_3V3	3.3V 彩色摄像头供电 3.3V RGB Camera Power Supply
3	IR_PWDN	红外摄像头电源控制 IR Camera Power Down
4	IR_RST	红外摄像头复位 IR Camera Reset
5	I2C_SCL	I2C 时钟线 I2C Clock
6	I2C_SDA	I2C 数据线 I2C Data
7	GND	数字地 Digital Ground
8	IR_MCLK	红外摄像头主时钟 IR Camera Main Clock
9	GND	数字地 Digital Ground
10	IR_MCP	红外摄像头 MIPI 差分时钟+ IR Camera MIPI Clock Positive
11	IR_MCN	红外摄像头 MIPI 差分时钟- IR Camera MIPI Clock Negative
12	GND	数字地 Digital Ground
13	IR_MDPO	红外摄像头 MIPI 差分数据0+ IR Camera MIPI Data0 Positive
14	IR_MDNO	红外摄像头 MIPI 差分数据0- IR Camera MIPI Data0 Negative
15	GND	数字地 Digital Ground
16	IR_MDP1	红外摄像头 MIPI 差分数据1+ IR Camera MIPI Data1 Positive
17	IR_MDN1	红外摄像头 MIPI 差分数据1- IR Camera MIPI Data1 Negative

18	GND	数字地 Digital Ground
19	DOVDD_1V8	1.8V 电源供电 1.8V Power Supply
20	FSIN	控制 sensor 同步, 控制 IO=#107 Control sensor synchronization, control IO=#107
21	LED_IO	双目 LED_5V, 控制 IO=#108 Binocular LED_5V, control IO=#108
22	IR_DVDD_1V2	1.2V 电源供电 1.2V Power Supply
23	RGB_DVDD_1V2	1.2V 电源供电 1.2V Power Supply
24	RGB_PWDN	彩色摄像头电源控制 RGB Camera Power Down
25	RGB_RST	彩色摄像头复位 RGB Camera Reset
26	GND	数字地 Digital Ground
27	RGB_MCLK	彩色摄像头主时钟 RGB Camera Main Clock
28	GND	数字地 Digital Ground
29	RGB_MCP	彩色摄像头 MIPI 差分时钟+ RGB Camera MIPI Clock Positive
30	RGB_MCN	彩色摄像头 MIPI 差分时钟- RGB Camera MIPI Clock Negative
31	GND	数字地 Digital Ground
32	RGB_MDP0	彩色摄像头 MIPI 差分数据0+ RGB Camera MIPI Data0 Positive
33	RGB_MDN0	彩色摄像头 MIPI 差分数据0- RGB Camera MIPI Data0 Negative
34	GND	数字地 Digital Ground
35	RGB_MDP1	彩色摄像头 MIPI 差分数据1+ RGB Camera MIPI Data1 Positive
36	RGB_MDN1	彩色摄像头 MIPI 差分数据1- RGB Camera MIPI Data1 Negative
37	GND	数字地 Digital Ground
38	VCC_5V	5V 电源供电 5V Power Supply
39	VCC_5V	5V 电源供电 5V Power Supply
40	VCC_5V	5V 电源供电 5V Power Supply

➤ J36 HDMI 输入插座 HDMI Input Jack

【J36】标准 HDMI 输入插座。 [J36] Standard HDMI Input Socket.

➤ J37 数据串口 2 Data Serial Port 2

【J37】内置串口 2 (单排 2.0mm-方孔为 1 脚), 默认为 RS-232 电平且可配置为 TTL/RS-485 电平 (焊接 U45 则为 RS-232 电平, 焊接 U48 则为 RS-485 电平); 对应的软件编程设备节点为 **ttyS2**。 [J37] Built-in Serial Port 2 (SIP 2.0mm-Square pad is pin 1). The output level is RS-232 by default and it could be setup to TTL/RS-485 if required (RS-232 if U45 mounted, RS-485 if U48 mounted). **The related software device node name is ttyS2.** 注: 该接口的丝印 COM3 是错误的。

Pin#	Definition	Note
1	GND	数字地 Digital Ground
2	RX	数据接收 (TTL/RS-232/RS-485) Data receive (TTL or RS-232 or RS-485 level)
3	TX	数据发送 (TTL/RS-232/RS-485) Data transmit (TTL or RS-232 or RS-485 level)

4	VCC	电源输出 (默认3.3V, 可选5V) Power output (Default 3.3V, 5V option)
---	-----	--

注意: **J37 COM2 与 J39 DB-9 COM2 复用, 两者无法同时使用。**如需将调试串口作为数据串口使用, 则请联系供应商获取定制版本软件; 在上电的前 5 秒此串口会输出启动信息 (上位机或下位机需要处理数据容错)。Note: If you need to use the debugging serial port as a data serial port, please contact the supplier to obtain the customized software; this serial port will output the startup information in the first 5 seconds of power on (the upper or lower machine should handle this kind of data fault tolerance).

➤ J38 数据串口 3 Data Serial Port 3

【J38】内置串口 3 (单排 2.0mm-方孔为 1 脚), 默认为 RS-232 电平且可配置为 TTL/RS-485 电平 (焊接 U45 则为 RS-232 电平, 焊接 U49 则为 RS-485 电平); **对应的软件编程设备节点为 ttyS3。** [J38] Built-in Serial Port 3 (SIP 2.0mm-Square pad is pin 1). The output level is RS-232 by default and it could be setup to TTL/RS-485 if required (RS-232 if U45 mounted, RS-485 if U49 mounted). **The related software device node name is ttyS3.** 注: 该接口的丝印 **COM2 是错误的。**

Pin#	Definition	Note
1	GND	数字地 Digital Ground
2	RX	数据接收 (TTL/RS-232/RS-485) Data receive (TTL or RS-485 level)
3	TX	数据发送 (TTL/RS-232/RS-485) Data transmit (TTL or RS-485 level)
4	VCC	电源输出 (默认3.3V, 可选5V) Power output (Default 3.3V, 5V option)

注意: **J38 COM3 与 J39 DB-9 COM3 复用, 两者无法同时使用。**

➤ J39 双层 DB-9 内置串口 Double DB-9 Serial Port

【J39】双层 DB-9 公头内置串口 COM2/COM3。上层是 COM3, 默认为 RS-232 电平且可配置为 TTL/RS-485 电平 (焊接 U45 则为 RS-232 电平, 焊接 U49 则为 RS-485 电平), **对应的软件编程设备节点为 ttyS3;** 下层是 COM2, 默认为 RS-232 电平且可配置为 TTL/RS-485 电平 (焊接 U45 则为 RS-232 电平, 焊接 U48 则为 RS-485 电平), **对应的软件编程设备节点为 ttyS2。** [J39] Double DB-9 male built-in Serial Port COM2/COM3. The upper layer is COM3, the output level is RS-232 by default and it could be setup to TTL/RS-485 if required (RS-232 if U45 mounted, RS-485 if U49 mounted). **The related software device node name is ttyS3.** The lower level is COM2, the output level is RS-232 by default and it could be setup to TTL/RS-485 if required (RS-232 if U45 mounted, RS-485 if U48 mounted). **The related software device node name is ttyS2.**

Pin#	Definition	Note
1	NC	未连接 Not Connected
2	RX	数据接收 (RS-232电平) Data receive (RS-232 level)

3	TX	数据发送 (RS-232电平) Data transmit (RS-232 level)
4	NC	未连接 Not Connected
5	GND	数字地 Digital Ground
6	NC	未连接 Not Connected
7	NC	未连接 Not Connected
8	NC	未连接 Not Connected
9	NC	未连接 Not Connected

注意：本端口带信号和电源完全隔离，可用于工业环境使用。DB-9 COM2 与 J38 COM2 复用，DB-9 COM4 与 J37 COM3 复用，复用的串口无法同时使用。

➤ J40 数据串口 4 Data Serial Port 4

【J40】内置串口 4（单排 2.0mm-方形为 1 脚），默认为 RS-485 电平且可配置为 TTL/RS-232 电平（焊接 U46 则为 RS-232 电平，焊接 U47 则为 RS-485 电平）；**对应的软件编程设备节点为 ttyS4。** [J40] Built-in Serial Port 4 (SIP 2.0mm-Square pad is pin 1). The output level is RS-485 by default and it could be setup to TTL/RS-232 if required (RS-232 if U46 mounted, RS-485 if U47 mounted). **The related software device node name is ttyS4.**

Pin#	Definition	Note
1	GND	数字地 Digital Ground
2	RX	数据接收 (TTL 或 RS-232) Data receive (TTL or RS-232 level)
3	TX	数据发送 (TTL 或 RS-232) Data transmit (TTL or RS-232 level)
4	VCC	电源输出 (默认3.3V, 可选5V) Power output (Default 3.3V, 5V option)

➤ J41 数据串口 5 Data Serial Port 5

【J41】内置串口 5（单排 2.0mm-方形为 1 脚），默认为 RS-485 电平且可配置为 TTL/RS-232 电平（焊接 U46 则为 RS-232 电平，焊接 U50 则为 RS-485 电平）；**对应的软件编程设备节点为 ttyS5。** [J41] Built-in Serial Port 5 (SIP 2.0mm-Square pad is pin 1). The output level is RS-485 by default and it could be setup to TTL/RS-232 if required (RS-232 if U46 mounted, RS-485 if U50 mounted). **The related software device node name is ttyS5.**

Pin#	Definition	Note
1	GND	数字地 Digital Ground
2	RX	数据接收 (TTL 或 RS-232) Data receive (TTL or RS-232 level)
3	TX	数据发送 (TTL 或 RS-232) Data transmit (TTL or RS-232 level)
4	VCC	电源输出 (默认3.3V, 可选5V) Power output (Default 3.3V, 5V option)

➤ J42 数据串口 7 Data Serial Port 7

【J42】内置串口 7（单排 2.0mm-方形为 1 脚），默认为 TTL 电平且可配置为 RS-232 电平（焊接 U9841 则为 RS-232 电平）；**对应的软件编程设备节点为 ttyS7**。[J42] Built-in Serial Port 7 (SIP 2.0mm-Square pad is pin 1). The output level is TTL by default and it could be setup to RS-232 if required (RS-232 if U9841 mounted). **The related software device node name is ttyS7. 注：该接口的丝印 COM6 是错误的。**

Pin#	Definition	Note
1	GND	数字地 Digital Ground
2	RX	数据接收 (TTL 或 RS-232) Data receive (TTL or RS-232 level)
3	TX	数据发送 (TTL 或 RS-232) Data transmit (TTL or RS-232 level)
4	VCC	电源输出 (默认3.3V, 可选5V) Power output (Default 3.3V, 5V option)

➤ J43 数据串口 8 Data Serial Port 8

【J43】内置串口 8（单排 2.0mm-方形为 1 脚），默认为 TTL 电平且可配置为 RS-232 电平（焊接 U9841 则为 RS-232 电平）；**对应的软件编程设备节点为 ttyS8**。[J43] Built-in Serial Port 8 (SIP 2.0mm-Square pad is pin 1). The output level is TTL by default and it could be setup to RS-232 if required (RS-232 if U9841 mounted). **The related software device node name is ttyS8. 注：该接口的丝印 COM7 是错误的。**

Pin#	Definition	Note
1	GND	数字地 Digital Ground
2	RX	数据接收 (TTL 或 RS-232) Data receive (TTL or RS-232 level)
3	TX	数据发送 (TTL 或 RS-232) Data transmit (TTL or RS-232 level)
4	VCC	电源输出 (默认3.3V, 可选5V) Power output (Default 3.3V, 5V option)

➤ J44 数据串口 9 Data Serial Port 9

【J44】内置串口 9（单排 2.0mm-方形为 1 脚），默认为 TTL 电平且可配置为 RS-232 电平（焊接 U9842 则为 RS-232 电平）；**对应的软件编程设备节点为 ttyS9**。[J44] Built-in Serial Port 9 (SIP 2.0mm-Square pad is pin 1). The output level is TTL by default and it could be setup to RS-232 if required (RS-232 if U9842 mounted). **The related software device node name is ttyS9. 注：该接口的丝印 COM8 是错误的。**

Pin#	Definition	Note
1	GND	数字地 Digital Ground
2	RX	数据接收 (TTL 或 RS-232) Data receive (TTL or RS-232 level)
3	TX	数据发送 (TTL 或 RS-232) Data transmit (TTL or RS-232 level)
4	VCC	电源输出 (默认3.3V, 可选5V) Power output (Default 3.3V, 5V option)

➤ J45 I2C 总线接口 I2C Bus Header

【J45】I2C 总线接口（单排 2.0mm-方孔为 1 脚）。[J45] I2C Bus Header (SIP 2.0mm-Square pad is pin 1).

Pin#	Definition	Note
1	GND	数字地 Digital Ground
2	INT	中断输入 (3.3V 电平) Interrupt input (3.3V level)
3	SDA	I2C 总线数据信号 I2C Bus data
4	SCL	I2C 总线时钟信号 I2C Bus clock signal
5	RST	复位输出 (3.3V 电平) Mainboard reset output (3.3V level)
6	3V3	3.3V 供电输出 Power output supply 3.3V

➤ J46 I2C FPC 接口 I2C FPC Header

【J46】I2C 总线接口（FPC-0.5mm 前插后翻盖**上/下接触**-三角为 1 脚）。[J46] I2C Bus Header (FPC-0.5mm **Top/Bottom Contact Triangle Pin-1**).

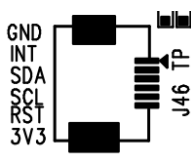

Pin#	Definition	Note
1	GND	数字地 Digital Ground
2	INT	中断输入 (3.3V 电平) Interrupt input (3.3V level)
3	SDA	I2C 总线数据信号 I2C Bus data
4	SCL	I2C 总线时钟信号 I2C Bus clock signal
5	RST	复位输出 (3.3V 电平) Mainboard reset output (3.3V level)
6	3V3	3.3V 供电输出 Power output supply 3.3V

➤ J47 CAN 接口 1 CAN Header 1

【J47】CAN 接口 1（单排 2.0mm-方形为 1 脚）。[J47] CAN Header 1 (SIP 2.0mm-Square pad is pin 1).

Pin#	Definition	Note
1	GND	数字地 Digital Ground
2	L1	L 数据 L Data
3	H1	L 数据 L Data
4	VCC	电源输出 (默认3.3V, 可选5V) Power output (Default 3.3V, 5V option)

注意：CAN1 口软件对应接口为 can0；需使用此接口请焊接 U9840 芯片；需要一路 CAN 请默认焊接此路芯片。

➤ J48 CAN 接口 2 CAN Header 2

【J48】CAN 接口 2（单排 2.0mm-方形为 1 脚）。[J48] CAN Header 2 (SIP 2.0mm-Square pad is pin 1)

Pin#	Definition	Note
1	GND	数字地 Digital Ground
2	L2	L 数据 L Data
3	H2	L 数据 L Data
4	VCC	电源输出（默认3.3V，可选5V） Power output (Default 3.3V, 5V option)

注意：CAN2 口软件对应接口为 can1；需使用此接口请焊接 U51 芯片；需要两路 CAN 请加焊此路芯片。

➤ PWR/HDD 双层 LED 灯 Dual-Tier LED

【PWR/HDD】用户自定义双层 LED 灯，下层电源 LED 灯（上电即亮）；上层运行 LED 灯（开机点亮可软件控制闪烁）。[J60] User defined dual-tier LED. Lower power LED light (on the power); Upper level LED lights (flicker controlled by software after turning on).

➤ SW1 系统复位按键 System Reset Button

【SW1】直插复位小按键，按一下即可重启系统。[SW1] On-board reset mode button. Click to restart the system.

➤ SW2 烧录模式按键 Recovery Mode Button

【SW2】直插烧录小按键，先按住且保持然后上电约 3 秒后松开则进入烧录模式。[SW2] On-board recovery mode button. First press and then hold for about 3-second while power on will enter the recovery mode.

5 物理尺寸 Physical Size

PCB 大小为 170mm*170mm, PCBA 高度 30.7mm, 固定的孔位直径 3.3mm, 相应的物理尺寸参数如下图所示。如需详细尺寸信息请咨询厂家索取 DXF 文档文件。

The PCB size is 170mm*170mm, PCBA height is 30.7mm, fixed hole diameter is 3.3mm. The corresponding physical size parameters are shown in the figure below. For detailed size information, please consult the manufacturer for DXF file.

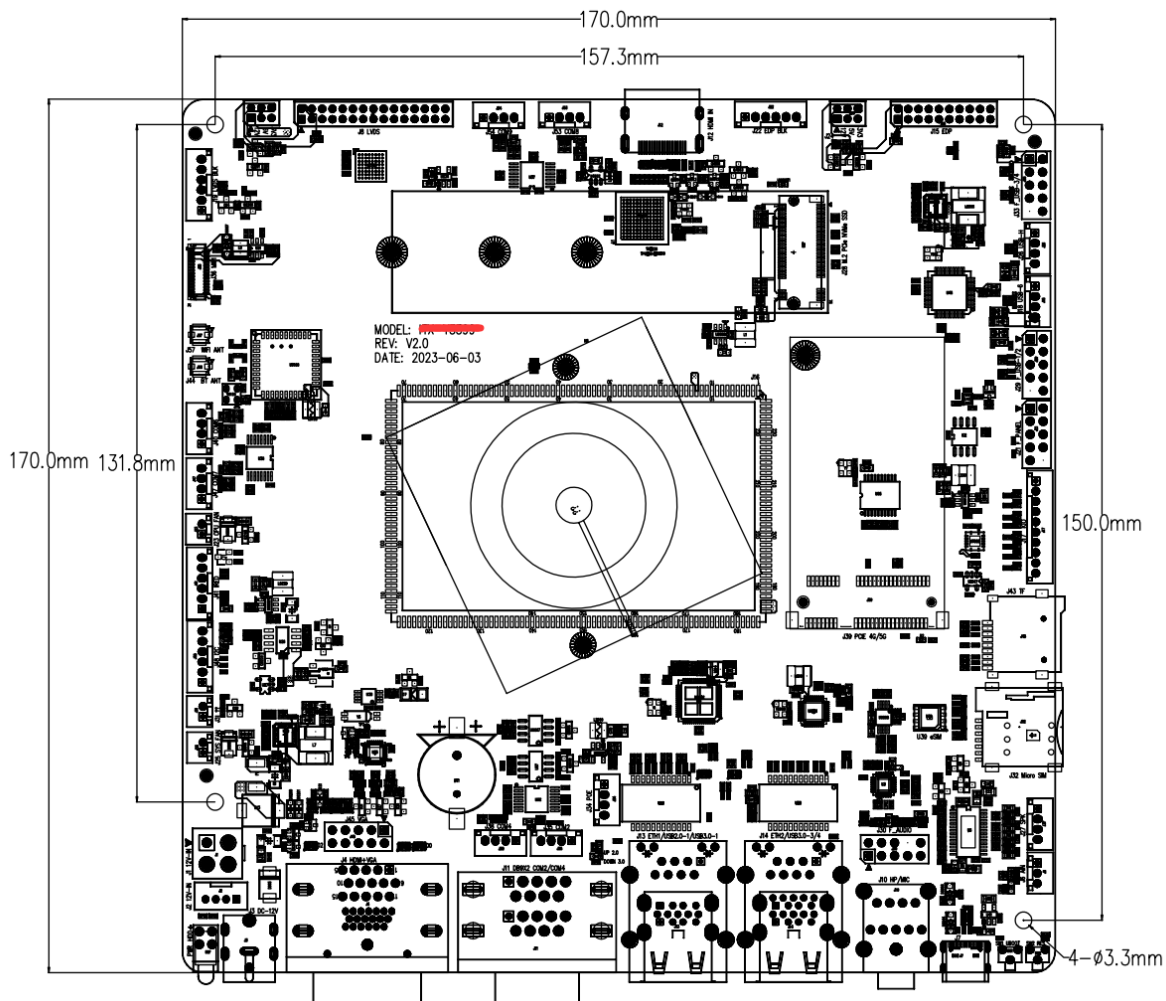

6 注意事项 Assemble Precautions

ITX-Y3568 主板组装和使用时请注意以下关键事项: Please note the following key points when using the ITX-Y3568 mainboard:

1. 本产品相对湿度: 10% ~ 90%, 无凝露。Relative humidity of this product: 10% to 90%, no condensation.
2. 本产品工作温度: -20°C ~ 70°C。The working temperature of this product: -20°C ~ 70°C.
3. 本产品存储温度: -40°C ~ 70°C。This storage temperature of this product: -40°C ~ 70°C.
4. 整机装配和运输过程中需做防静电处理。Anti-static treatment is required during assembly and transportation of this product.
5. 本板接口连接线缆不可过长, 否则可能会影响信号质量。The board interface connection cable must not be too long. Otherwise, the signal quality may be affected.
6. 整机装配时严禁使板子受到扭曲或重压而变形。Never allow the board to be distorted or heavily stressed during assembly.
7. 严禁裸板与其他外设之间发生短路。Do not short circuit between mainboard and other peripherals.
8. 外接 LVDS 或 eDP 液晶屏时, 注意驱屏电压和电流是否符合要求, 且注意屏线插座 1 脚方向。When connecting to external LVDS or eDP LCD screen, pay attention to whether the screen voltage and current meet the requirements, and pay attention to the screen connector pin-1 direction.
9. 外接 LVDS 或 eDP 液晶屏时, 注意背光电压和电流是否符合要求。**液晶屏背光功率在 20W 以上则建议使用单独的电源板进行背光供电。**When connecting to external LVDS or eDP LCD screen, pay attention to whether the backlight voltage and current meet the requirements.
10. 外接接口 (USB、GPIO、串口、I2C、SPI、HDMI 等) 外接设备时, 注意外设的 IO 电平和电流是否符合要求。**使用主板接插件上的电源管脚给外设供电时, 常规电源脚电流严禁超过 100mA、USB 电源脚电流严禁超过 500mA。**串口连接外设时还需要电平匹配 (3.3V TTL 电平、RS-232 电平和 RS-485 电平)。When connecting to peripherals using USB, GPIO, Serial, I2C, SPI, HDMI, etc., pay attention to whether the IO voltage level and current of the peripheral meet the requirements. When using the power pin on these connectors to

supply power to the external circuit, the regular power pin must not exceed 100mA, and the USB power pin must not exceed 500mA.

11. 主板输入电源请务必接入电源输入接口或插座, 并根据总外设评估整板电流是否符合要求; **严禁为了方便操作从背光插座接口直接给主板供电**。Please connect the power to the power input socket or connector, and evaluate whether the current of the whole board meets the requirements according to the total peripherals. It is strictly forbidden to directly supply power from the backlight connector.
12. 通信模块部分距离金属壳体至少 5 毫米, 避免信号受到干扰。The communication module should be mounted at least 5mm away from the metal housing to avoid signal interference.

7 软件指南 Software Guide

ITX-Y3568 主板支持 LVDS/EDP/MIPI/HDMI/VGA 任意两种输出的双屏异显组合! 相关输出组合请咨询厂家提供相应的异显补丁。

ITX-Y3568 主板内部串口和扩展串口软件端口号如下:

端口 Port	软件设备节点 Software Device Node
J37	/dev/ttyS2
J38	/dev/ttyS3
J39	/dev/ttyS2(下层)+/dev/ttyS3(上层)
J40	/dev/ttyS4
J41	/dev/ttyS5
J42	/dev/ttyS7
J43	/dev/ttyS8
J44	/dev/ttyS9